

## Wireless Carbon Monoxide (CO) Sensor

### General Description

The Wireless Carbon Monoxide (CO) sensor allows you to monitor the level of carbon monoxide (CO) gas in the surrounding air.

Monnit wireless CO sensors have a small footprint and low cost but boast industry standard setting, premium performance specifications and are the longest lifetime sensors in the industry (powered by a coin cell battery and last over a year at 1 hour heartbeat)

- Measures CO levels in surrounding air.



Free iMonnit basic online wireless sensor monitoring and notification system to configure sensors, view data and set alerts via SMS text and email.

### Principle of Operation

The Wireless Carbon Monoxide (CO) Sensor measures the amount of CO gas in the surrounding air. The sensor returns carbon monoxide level and temperature values to the iMonnit Online Sensor Monitoring and Notification System. The system stores both data points in the online system where the data can be reviewed and exported as a data sheet or graph. Notifications can be set up through the online system to alert the user when defined CO levels have been met or exceeded.

### Example Applications

- Gas ranges and ovens
- Gas clothes dryers
- Furnaces
- Fireplaces
- Grills
- Space heaters
- Vehicles
- Water heaters

And many more...

### Monnit Sensor Core Specifications

- Wireless Range: 250 - 300 ft. (non-line-of-sight / indoors / through walls, ceilings & floors) \*
- RF Communication: 900, 920, 868 and 433 MHz
- Power: Replaceable batteries (optimized for long battery life, line-power options are available)
- Battery Life (at 1 hour heartbeat setting): \*\*
  - AA battery > 4-8 years
  - Coin Cell > 2-3 years.

\* Actual range may vary depending on environment.

\*\* Battery life is determined by sensor reporting frequency and other variables.

### Sensor Types & Options

Wireless Carbon Monoxide (CO) Sensor (AA)	2
Wireless Carbon Monoxide (CO) Sensor (Coin Cell)	3
Notes	4

## Wireless Carbon Monoxide (CO) Sensor (AA)

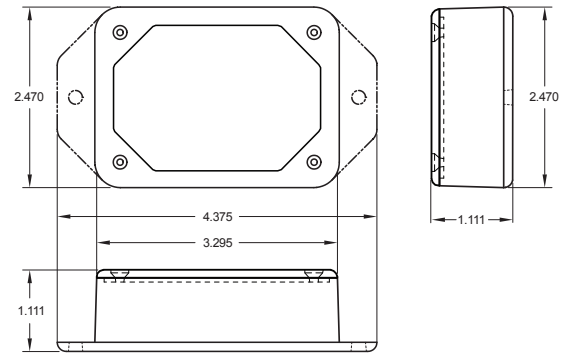

### Technical Specifications

Supply Voltage	2.0 - 3.6 VDC (3.0 - 3.6 VDC Using Power Supply) *
Current Consumption	0.7 $\mu$ A (sleep mode) 2 mA (radio idle/off mode) 2 mA (measurement mode) 25 mA (radio RX mode) 35 mA (radio TX mode)
Operating Temperature Range (Board Circuitry and Batteries)	-18°C to 55°C (0°F to 130°F) using alkaline -40°C to 85°C (-40°F to 185°F) using lithium **
Optimal Battery Temperature Range (AA)	+10°C to +50°C ( +50°F to +122°F )
Operating Pressure Range	$\pm$ 0.2 atm (recommended)
Operating Humidity Range	15 to 85% RH
Measuring Range	0-500 PPM
Maximum Overload	1500 PPM
Measuring Principle	Electrochemical Oxidation of CO
Resolution	$\pm$ 0.5 PPM
Response Time (t-90)	< 30 seconds typical at 20°C
Stabilization Time	< 30 seconds
Long Term Drift – Zero	Zero Signal $\leq$ $\pm$ 2 PPM / month
Long Term Drift – Span	Output Signal $\leq$ $\pm$ 2% of reading per month
Maximum Zero Shift	< 8 ppm equivalent (-20°C to +40°C)
Weight	4.0 oz.
Wireless Range	250 - 300 ft. (Indoors / Through walls, ceilings & floors) Range may vary according to environmental variables.
Certifications	900 MHz product; FCC ID: ZTL- RFSC1 and IC: 9794A-RFSC1. 920 MHz product; ARIB STD-T108 R210-103733. 868 and 433 MHz product tested and found to comply with: CISPR 22:2008-09 / EN 55022:2010 - Class B and ETSI EN 300 220-2 V2.4.1 (2012-05).

\* Hardware cannot withstand negative voltage. Please take care when connecting a power device.

\*\* At temperatures above 100°C, it is possible for the board circuitry to lose programmed memory.

### Power Options

Two replaceable 1.5V AA sized batteries are included with the standard model. A line-power version with battery backup is also available - allowing it to be powered by a standard 3.0 - 3.6V power supply and use the internal batteries if there is a power interruption.

Power options must be selected at time of purchase as the internal hardware of the sensor must be changed to support the selected power requirements.

# Wireless Carbon Monoxide (CO) Sensor (Coin Cell)

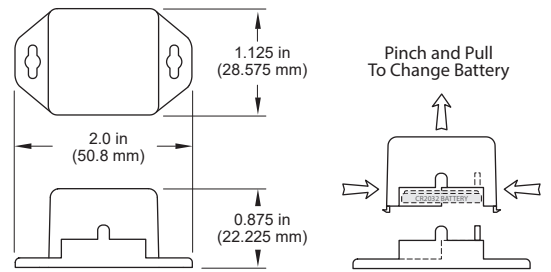

Technical Specifications	
Supply Voltage	2.0 - 3.6 VDC *
Current Consumption	0.7 $\mu$ A (sleep mode) 2 mA (radio idle/off mode) 2 mA (measurement mode) 25 mA (radio RX mode) 35 mA (radio TX mode)
Operating Temperature Range (Board Circuitry and Coin Cell)	-7°C to +60°C ( 20°F to +140°F )**
Optimal Battery Temperature Range (Coin Cell)	+10°C to +50°C ( +50°F to +122°F )
Operating Pressure Range	$\pm$ 0.2 atm (recommended)
Operating Humidity Range	15 to 85% RH
Measuring Range	0-500 PPM
Maximum Overload	1500 PPM
Measuring Principle	Electrochemical Oxidation of CO
Resolution	$\pm$ 0.5 PPM
Response Time (t-90)	< 30 seconds typical at 20°C
Stabilization Time	< 30 seconds
Long Term Drift – Zero	Zero Signal $\leq$ $\pm$ 2 PPM / month
Long Term Drift – Span	Output Signal $\leq$ $\pm$ 2% of reading per month
Maximum Zero Shift	< 8 ppm equivalent (-20°C to +40°C)
Weight	1.0 oz.
Wireless Range	250 - 300 ft. (Indoors / Through walls, ceilings & floors) Range may vary according to environmental variables.
Certifications	900 MHz product; FCC ID: ZTL- RFSC1 and IC: 9794A-RFSC1. 920 MHz product; ARIB STD-T108 R210-103733. 868 and 433 MHz product tested and found to comply with: CISPR 22:2008-09 / EN 55022:2010 - Class B and ETSI EN 300 220-2 V2.4.1 (2012-05).



\* Hardware cannot withstand negative voltage. Please take care when connecting a power device.  
 \*\* At temperatures above 100°C, it is possible for the board circuitry to lose programmed memory.

## Power Options

Sensors are powered by a replaceable 3.0 V coin cell battery. Optional AA battery powered sensors are available. The AA version of these sensors are larger in size (3" [L] x 2.1" [W] x 1.2" [H] ) and include two long-life AA batteries.

It is recommended that unless you are using the AA battery solution, you set heartbeat to no faster than one hour to preserve battery life.

## PinchPower™ Enclosure

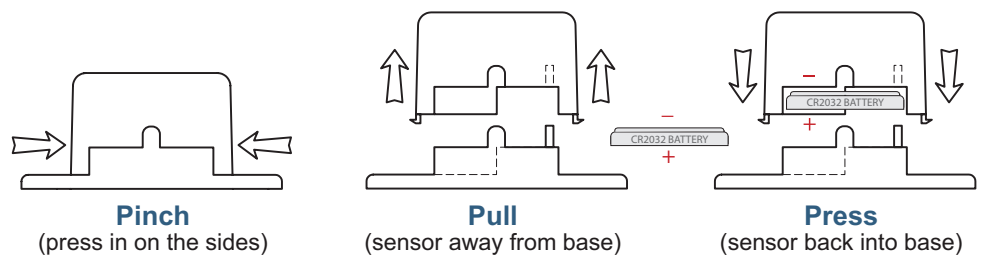

## Notes

### Commercial Grade Sensors

Monnit commercial grade sensors are designed for applications in ordinary environments (normal room temperature, humidity and atmospheric pressure). Do not use these sensors under the following conditions as these factors can deteriorate the product characteristics and cause failures and burn-out.

- Corrosive gas or deoxidizing gas - chlorine gas, hydrogen sulfide gas, ammonia gas, sulfuric acid gas, nitric oxides gas, etc.).
- Volatile or flammable gas.
- Dusty conditions.
- Under low or high pressure.
- Wet or excessively humid locations.
- Places with salt water, oils chemical liquids or organic solvents.
- Where there are excessively strong vibrations.
- Other places where similar hazardous conditions exist.

Use these products within the specified temperature range. Higher temperature may cause deterioration of the characteristics or the material quality.

### Industrial Grade Sensors - Type 1, 2, 4, 4X, 12 and 13 NEMA Rated Enclosure

Monnit's Industrial sensors are enclosed in reliable, weatherproof NEMA rated enclosures. Our NEMA rated enclosures are constructed for both indoor or outdoor use and protect the sensor circuitry against the ingress of solid foreign objects like dust as well as the damaging effects of water (rain, sleet, snow, splashing water, and hose directed water).

- Safe from falling dirt.
- Protects against wind-blown dust.
- Protects against rain, sleet, snow, splashing water, and hose directed water
- Increased level of corrosion resistance
- Will remain undamaged by ice formation on the enclosure



For more information about our products or to place an order, please contact our sales department at 801-561-5555.

Visit us on the web at [www.monnit.com](http://www.monnit.com).

Monnit Corporation  
3400 South West Temple  
Salt Lake City, UT 84115  
801-561-5555  
[www.monnit.com](http://www.monnit.com)