



Wireless AC Current Meter

General Description

The wireless AC Current Meter measures the RMS current of an alternating current (AC) system using a current transformer (CT) that wraps around the “hot” wire of a two wire (hot, common, ground(optional)) power system. The sensor will report the Minimum RMS current, maximum RMS current, average RMS current, and amp hours to the iMonnit system. The online iMonnit system is capable of generating watt hour or kilowatt hour readings as well.

- Measures amp hours, max RMS current, min RMS current, and average RMS current.
- Two different current transducers available:
 - Low Current: 0-20 Amp
 - High Current: 0-150 Amp
- Capable of generating Watt Hour or Kilowatt Hour readings using iMonnit.
- Data logging for accumulated amp hour readings.
- Can notify based on current levels or changes in current levels.
- Simple and safe installation of current/power measurement hardware, no rewiring required.



Free iMonnit basic online wireless sensor monitoring and notification system to configure sensors, view data and set alerts via SMS text and email.

Principle of Operation

To measure current, clip the CT around only a single wire of the AC system (clipping around a hot and neutral wire at the same time will result in 0 current readings). After the sensor powers on and connects gateway it will begin collecting measurements based upon the average interval (5 seconds default). The sensor will relay data to iMonnit every heartbeat or if the current goes outside of the aware thresholds set in iMonnit. The sensor reports amp hours, max RMS current, min RMS current, and average RMS current. iMonnit can also generate watt hour or kilowatt hour readings if a default RMS voltage is set in iMonnit.

Monnit Sensor Core Specifications

- Wireless Range: 250 - 300 ft. (non line-of-sight / indoors / through walls, ceilings & floors) *
- Communication: RF 900, 920, 868 and 433 MHz
- Power: Replaceable batteries (optimized for long battery life) - Line-power (AA version) and solar (Industrial version) options available
- Battery Life (at 1 hour heartbeat setting): **
 - AA battery > 4-8 years
 - Industrial > 4-8 years

* Actual range may vary depending on environment.

** Battery life is determined by sensor reporting frequency and other variables.

Applications

- Current Monitoring
- Current Usage
- Amperage Monitoring
- Amp Hour Meter

Sensor Types & Options

Wireless AC Current Meter (AA) 2

Wireless AC Current Meter (Industrial) 3

Notes 4

Wireless AC Current Meter (AA)

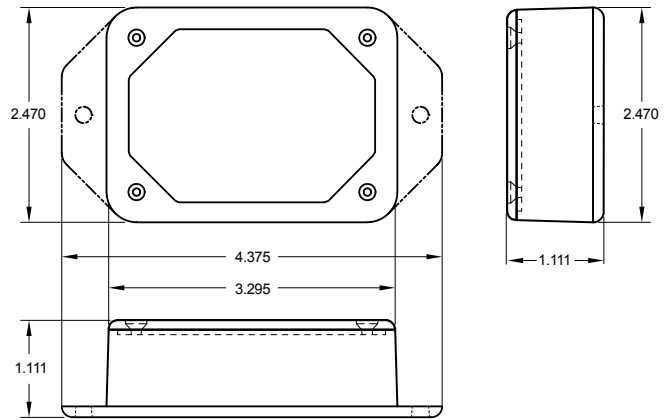

Technical Specifications

Supply Voltage	2.0 - 3.6 VDC (3.0 - 3.6 VDC Using Power Supply) *
Current Consumption	0.7 μ A (sleep mode) 2 mA (radio idle/off mode) 2 mA (measurement mode) 25 mA (radio RX mode) 35 mA (radio TX mode)
Operating Temperature Range (Board Circuitry and Batteries)	-18°C to 55°C (0°F to 130°F) using alkaline -40°C to 85°C (-40°F to 185°F) using lithium **
Optimal Battery Temperature Range (AA)	+10°C to +50°C (+50°F to +122°F)
Wireless Range	250 - 300 ft. (Indoors / Through walls, ceilings and floors) Range may vary according to environmental variables.
Certifications	900 MHz product; FCC ID: ZTL- RFSC1 and IC: 9794A-RFSC1. 920 MHz product; ARIB STD-T108 R210-103733. 868 and 433 MHz product tested and found to comply with: CISPR 22:2008-09 / EN 55022:2010 - Class B and ETSI EN 300 220-2 V2.4.1 (2012-05).



- * Hardware cannot withstand negative voltage. Please take care when connecting a power device.
** At temperatures above 100°C, it is possible for the board circuitry to lose programmed memory.

	0-20 Amp Model	0-150 Amp Model
Absolute Max CT Current	50 Amps RMS (A rms)	200 Amps RMS (A rms)
Maximum Accurate CT Current	20 A rms	150 A rms
Frequency Range	50 – 100 Hz	50 – 100 Hz
Accuracy	+/- (2% +.07 A rms)***	+/- (2% +.07 A rms)***
Calibrated Accuracy with Appropriate Offset	+/- (1% + .035 A rms) ***	+/- (1% + .035 A rms) ***
Offset Limits	-1.27 to + 1.27 A rms (default set to +.1 A rms) ****	-1.27 to + 1.27 A rms (default set to +.3 A rms) ****
Measurement Resolution	~.01 A rms	~.1 A rms
Current Transducer Dimensions	40mm x 25mm x 26mm (10mm inner diameter)	67mm x 49mm x 42mm (24mm inner diameter)
Weight	2.10 ounces (CT only)	7.27 ounces (CT only)
Lead Length	3 feet	3 feet.

*** CTs are inherently less accurate at or below 10% of max range. For best results; calibrate at a current between 30% and 90% of max accurate range.
**** Offset is used to overcome a diode voltage drop inherent to the hardware. To accurately account for this drop a default offset is used. To best identify the optimal value of this offset; make a series of measurements at .2 to 2 Arms and find the current (Arms) difference between your measurement standard and the Monnit sensor.

Power Options

Two replaceable 1.5V AA sized batteries are included with the standard model. A line-power version with battery backup is also available - allowing it to be powered by a standard 3.0 - 3.6V power supply and utilize the internal batteries if there is a power interruption.

Power options must be selected at time of purchase as the internal hardware of the sensor must be changed to support the selected power requirements.

Wireless AC Current Meter (Industrial)

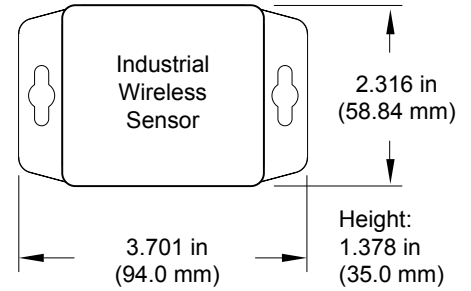

Technical Specifications		
Supply Voltage	2.0 - 3.6 VDC *	
Current Consumption	0.7 μ A (sleep mode) 2 mA (radio idle/off mode) 2 mA (measurement mode) 25 mA (radio RX mode) 35 mA (radio TX mode)	
Operating Temperature Range (Board Circuitry and Battery)		
Included Battery	Max Temperature Range:	-40° to +85°C (-40° to +185°F) **
	Capacity:	5000 mAh
Optional Solar Feature	Solar Panel:	5VDC / 30mA (53mm x 30mm)
	Charging Temperature Range:	0° to 45°C (32° to 113°F)
	Max Temperature Range:	-20° to 60°C (-4° to 140°F)
	Included Rechargeable Battery:	600 mAh / >2000 Charge Cycles (80% of initial capacity)
Wireless Range	250 - 300 ft. (Indoors / Through walls, ceilings and floors) Range may vary according to environmental variables.	
Enclosure Rating	NEMA 1, 2, 4, 4x, 12 and 13 rated, weather proof.	
UL Rating	UL Listed to UL508-4x specifications (File E194432)	
Certifications	900 MHz product; FCC ID: ZTL- RFSC1 and IC: 9794A-RFSC1. 920 MHz product; ARIB STD-T108 R210-103733. 868 and 433 MHz product tested and found to comply with: CISPR 22:2008-09 / EN 55022:2010 - Class B and ETSI EN 300 220-2 V2.4.1 (2012-05).	



- * Hardware cannot withstand negative voltage. Please take care when connecting a power device.
- ** At temperatures above 100°C, it is possible for the board circuitry to lose programmed memory.
- *** Solar feature is only chargeable outside in full sunlight.

	0-20 Amp Model	0-150 Amp Model
Absolute Max CT Current	50 Amps RMS (A rms)	200 Amps RMS (A rms)
Maximum Accurate CT Current	20 A rms	150 A rms
Frequency Range	50 – 100 Hz	50 – 100 Hz
Accuracy	+/- 2% @ 2 to 20 A rms, +/- .07 A rms @ < 2 A rms***	+/- 2% @ 2 to 150 A rms, +/- .4 A rms @ < 15 A rms***
Calibrated Accuracy with Appropriate Offset	+/- 1% @ 2 to 20 A rms, +/- .035 A rms @ < 2 A rms***	+/- 1% @ 2 to 150 A rms, +/- .2 A rms @ < 2 A rms***
Offset Limits	-1.27 to + 1.27 A rms (default set to +.1 A rms) ****	-1.27 to + 1.27 A rms (default set to +.3 A rms) ****
Measurement Resolution	~.01 A rms	~.1 A rms
Current Transducer Dimensions	40mm x 25mm x 26mm (10mm inner diameter)	67mm x 49mm x 42mm (24mm inner diameter)
Weight	2.10 ounces (CT only)	7.27 ounces (CT only)
Lead Length	3 feet	3 feet

*** CTs are inherently less accurate at or below 10% of max range. For best results; calibrate at a current between 30% and 90% of max accurate range.
 **** Offset is used to overcome a diode voltage drop inherent to the hardware. To accurately account for this drop a default offset is used. To best identify the optimal value of this offset; make a series of measurements at .2 to 2 Arms and find the current (Arms) difference between your measurement standard and the Monnit sensor.

Solar Power Option

Monnit Industrial Sensors are powered by a replaceable 3.6V Lithium battery (included). An optional solar powered version is also available. The solar powered sensor uses a Lithium Iron Phosphate rechargeable battery in conjunction with a solar power cell to extend battery life.

Notes

Commercial Grade Sensors

Monnit commercial grade sensors are designed for applications in ordinary environments (normal room temperature, humidity and atmospheric pressure). Do not use these sensors under the following conditions as these factors can deteriorate the product characteristics and cause failures and burn-out.

- Corrosive gas or deoxidizing gas - chlorine gas, hydrogen sulfide gas, ammonia gas, sulfuric acid gas, nitric oxides gas, etc.).
- Volatile or flammable gas.
- Dusty conditions.
- Under low or high pressure.
- Wet or excessively humid locations.
- Places with salt water, oils chemical liquids or organic solvents.
- Where there are excessively strong vibrations.
- Other places where similar hazardous conditions exist.

Use these products within the specified temperature range. Higher temperature may cause deterioration of the characteristics or the material quality.

Industrial Grade Sensors - Type 1, 2, 4, 4X, 12 and 13 NEMA Rated Enclosure

Monnit's Industrial sensors are enclosed in reliable, weatherproof NEMA rated enclosures. Our NEMA rated enclosures are constructed for both indoor or outdoor use and protect the sensor circuitry against the ingress of solid foreign objects like dust as well as the damaging effects of water (rain, sleet, snow, splashing water, and hose directed water).

- Safe from falling dirt.
- Protects against wind-blown dust.
- Protects against rain, sleet, snow, splashing water, and hose directed water
- Increased level of corrosion resistance
- Will remain undamaged by ice formation on the enclosure



For more information about our products or to place an order, please contact our sales department at 801-561-5555.

Visit us on the web at www.monnit.com.

Monnit Corporation
3400 South West Temple
Salt Lake City, UT 84115
801-561-5555
www.monnit.com