



Remote Monitoring for Business

ALTA® Wireless CO₂ - Carbon Dioxide Sensors

General Description

The [ALTA Wireless Carbon Dioxide Sensor](#) uses a low-power high-performance carbon dioxide (CO₂) sensing element to measure the amount of CO₂ in ambient air and report instantaneous and time-weighted average (TWA) readings.

Key Features

- ▶ Measurement Range: 0 to 10,000 ppm CO₂
- ▶ Resolution: 1 ppm
- ▶ Accuracy: +/- 45 ppm + 3% of reading
- ▶ Data:
 - ▶ Instantaneous CO₂
 - ▶ 8-hour time-weighted average (TWA) of CO₂
- ▶ Configurable thresholds for critical condition monitoring
- ▶ Configurable auto-calibration

Principles of Operation

The ALTA Wireless Carbon Dioxide Sensor measures the CO₂ level in the air using a non-dispersive infrared (NDIR) sensing element. The sensor reports data from the most recent measurement every user-configurable Heartbeat (report interval). This measurement is then sent to the gateway, making the data available in iMonnit or other approved data services.

The sensor also produces 8-hour TWA data by accumulating eight hours of instantaneous CO₂ readings and averaging them together.

Example Applications

- ▶ Indoor air quality
- ▶ [Greenhouses](#)
- ▶ Cellar and gas stores
- ▶ Marine vessels
- ▶ Modified atmospheres
- ▶ Landfill gas
- ▶ Confined spaces
- ▶ Cryogenics
- ▶ Ventilation management
- ▶ [Additional applications](#)

Features of Monnit ALTA Sensors

- Wireless range of 2,000+ feet through 18+ walls¹
- Frequency-Hopping Spread Spectrum (FHSS)
- Best-in-class interference immunity
- Best-in-class power management for longer battery life²
- Encrypt-RF® Security (Diffie-Hellman Key Exchange + Advanced Encryption Standard (AES)-128 Cipher Block Chaining (CBC) for sensor data messages)
- Sensor logs 2000 to 4000 readings if the gateway connection is lost (non-volatile flash, persists through power cycling):
 - 10-minute Heartbeats = ~ 22 days
 - 2-hour Heartbeats = ~ 266 days
- Automatic over-the-air updates to sensor firmware (future-proof)
- Free iMonnit Basic Online Wireless Sensor Monitoring and Notification System to configure sensors, view data, and send alerts via SMS text, email, and voice call

1 Actual range may vary depending on the environment and gateway.

2 Battery life is determined by the sensor reporting frequency and other variables. Other power options are also available.

Wireless Range Comparison

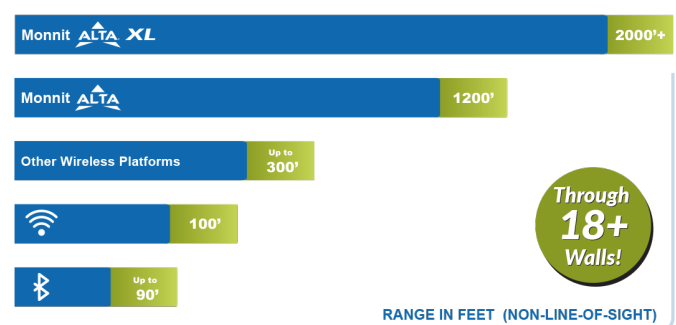

Technical Specification | ALTA® Wireless Carbon Dioxide Sensors

CO ₂ Measurement	Range (Instantaneous and TWA)	0 to 10000 ppm CO ₂
	Accuracy	+/- ((45 ppm + 3%) * (1 + .0013 * ΔP)) ¹
	Resolution	1 ppm ²
	Response time	3 minutes (63% of actual), 15 minutes (99.3% of actual)
	Repeatability	+/- ((45 ppm + 3%) * (1 + .0013 * ΔP)) ¹
	CO ₂ element operating temperature	0°C to 50°C (32°F to 122°F)
	CO ₂ element operating humidity	0 to 95% (non-condensing)
	CO ₂ element operating altitude	-1524 to 5547 m (-5000 to 18,200 ft) ²
	CO ₂ element storage temperature	-40°C to 70°C (-40°F to 158°F)
	CO ₂ element storage altitude	-5547 to 5547 m (-18200 to 18,200 ft) ²
	Pressure dependence	~0.14% of reading per mbar from sea level ²
	Calibration	Configurable auto-calibration ³
	Sample method	Diffusion
	Sensing method	Non-dispersive infrared (NDIR) absorption Gold-plated optics Solid-state source and detector
ALTA Wireless	Data logging	Sensor logs 2000 to 4000 readings if gateway connection is lost (non-volatile flash, persists through power cycling): 10-minute Heartbeats = ~22 days - 2-hour Heartbeats = ~266 days
	Wireless protocol	ALTA Proprietary Frequency-Hopping Spread Spectrum (FHSS)
	Wireless transmission power (EIRP)	50 mW (900MHz), 25 mW (868 MHz), 10 mW (433 MHz)
	Wireless range	2,000+ ft. through 18+ walls with the ALTA XL® Gateway
	Security	Encrypt-RF® (256-bit key exchange and AES-128 CTR)
General	Battery voltage range	2.0 to 3.8 VDC
	Operating altitude (non-pressurized environments)	-15.2 to 1,982 m (-50 to 6,500 ft) ⁴
	Storage altitude (non-pressurized environments)	-15.2 to 3,048 m (-50 to 10,000 ft) ⁴
	Operating humidity	5 to 85% RH (non-condensing)
	Certifications	900 MHz sensors: FCC ID: ZTL-G2SC1 and IC: 9794A-G2SC1 . 868 and 433 MHz sensors tested and comply with: EN 55032: 2015/A11:2020 ; EN 55035:2017/A11:2020 ; ETSI EN 300 220 V3.2.1 (2018-06) ; ETSI EN 301 489-3 V2.2.0. (2021-11) ; and ETSI EN 303 645 . All sensors tested and comply with: EN 61010-1 and EN 60950 and meet RoHS 2015/863 and REACH 224 (June 2022) , according to IEC 63000:2016/AMD1:2022 .



1. ΔP is in mbar and is the difference between atmospheric pressure at sea level (1013 mbar) and the pressure at the sensors altitude (Ex: 1013 mbar – ambient pressure in mbar).
2. The sensor has a user-configurable altitude calibration to compensate for atmospheric pressure levels other than sea level. As altitude is increased resolution increases and accuracy/repeatability decreases. As altitude is decreased the range may decrease but resolution, accuracy, and repeatability will improve.
3. For correct auto-calibration, the sensor must experience fresh air CO₂ levels (~400 ppm) for at least four hours per day. If the environment does not meet this criteria then disable the auto-calibration feature in settings.
4. Operating and storage altitude without DC power supply is -30.48 to 5547 m (-100 to 18200 ft).

The sensor reports CO₂ parts per million (ppm) and the 8-hour time-weighted average (TWA) of CO₂ in ppm.

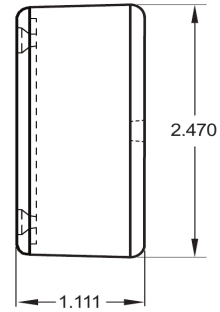
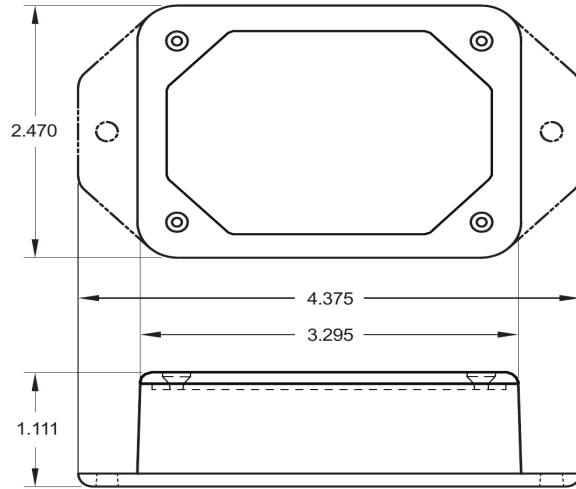

Technical Specifications | ALTA® Enterprise

Battery	2x 1.5V AA Alkaline, 1500 mAh, (standard) 2x 1.5V AA Lithium, 3000 mAh, (optional)
Battery Life	10+ years expected
External line-power option ¹	Input voltage: 5.0-12.0 V Power jack: 2.1 x 5.5 mm barrel, center positive
Operating temperature range ²	0°C to 50°C (32°F to 122°F) - AA Alkaline Batteries 0°C to 50°C (32°F to 122°F) - AA Lithium L91 Batteries 0°C to 40°C (32°F to 104°F) - US 5V Power Supply 10°C to 40°C (50°F to 104°F) - International 5V Power Supply
Wireless antenna type	1/4-wave, 20 gauge wire whip, 3.5" (900/868MHz), 7" (433MHz)
Weight	4.5 oz. (127 g)

1. Batteries will provide backup power in the case the external power is removed.
2. Operating below 0°C (-32°F) degrees will reduce battery life.

Commercial-Grade Sensors

Monnit commercial-grade sensors are designed for applications in ordinary environments (normal room temperature, humidity, and atmospheric pressure). Do not use these sensors under the following conditions as these factors can deteriorate the product characteristics and cause failures and burnout.

- Corrosive gas or deoxidizing gas: chlorine gas, hydrogen sulfide gas, ammonia gas, sulfuric acid gas, nitric oxide gas, etc.
- Volatile or flammable gas
- Dusty conditions
- Low-pressure or high-pressure environments
- Wet or excessively humid locations
- Places with salt water, oils, chemical liquids, or organic solvents
- Where there are excessively strong vibrations
- Other places where similar hazardous conditions exist

Use these products within the specified temperature range. Higher temperatures may cause deterioration of the characteristics or the material quality.



Monnit Corporation

3400 South West Temple • Salt Lake City, UT 84115 • 801-561-5555
www.monnit.com