



## ALTA® Wireless 5-Input Dry Contact Sensors

### General Description

[ALTA Wireless 5-Input Dry Contact Sensors](#) can be used to detect contact between multiple wired contact points, such as mechanical switches or relays, transistor switches, or contact plates. There are five inputs that detect contact independently and simultaneously.

### Key Features

- ▶ Cable length: 0.9 m (3')
- ▶ Cable terminations: bare-wire
- ▶ Can integrate with switches

### Principles of Operation

The ALTA Wireless 5-Input Dry Contact Sensor uses five input wires and one ground wire to detect when there is contact between any of the five inputs and the ground wire. It can easily be integrated into existing switches or contact plates. When the sensor detects contact between any of the five inputs and ground, wireless communication is immediately sent to the gateway. The gateway will immediately attempt to securely send the message to iMonnit or other approved data services.

The sensor can be configured to detect both closed and open loops for each of the five inputs, alerting if contact is made or broken and on state changes.

### Example Applications

- ▶ Facility and factory automation
- ▶ Barn door monitoring
- ▶ Freezer/cooler door monitoring
- ▶ Forklift seat switches
- ▶ Button or switch integration
- ▶ Production line tracking
- ▶ [Additional applications](#)

### Features of Monnit ALTA Sensors

- Wireless range of 2,000+ feet through 18+ walls<sup>1</sup>
- Frequency-Hopping Spread Spectrum (FHSS)
- Best-in-class interference immunity
- Best-in-class power management for longer battery life<sup>2</sup>
- Encrypt-RF® Security (Diffie-Hellman Key Exchange + Advanced Encryption Standard (AES)-128 Cipher Block Chaining (CBC) for sensor data messages)
- Sensor logs 2000 to 4000 readings if the gateway connection is lost (non-volatile flash, persists through power cycling):
  - 10-minute Heartbeats = ~ 22 days
  - 2-hour Heartbeats = ~ 266 days
- Automatic over-the-air updates to sensor firmware (future-proof)
- Free iMonnit Basic Online Wireless Sensor Monitoring and Notification System to configure sensors, view data, and send alerts via SMS text, email, and voice call

<sup>1</sup> Actual range may vary depending on the environment and gateway.

<sup>2</sup> Battery life is determined by the sensor reporting frequency and other variables. Other power options are also available.

### Wireless Range Comparison

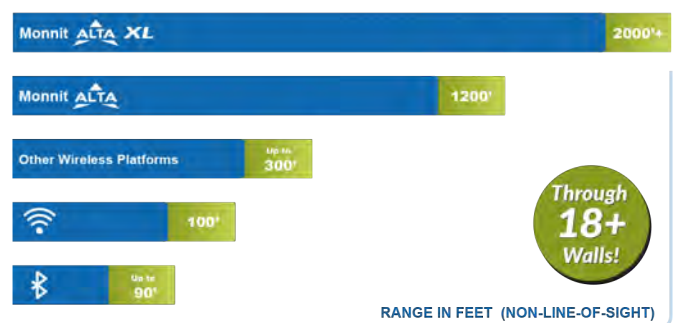

## Technical Specification | ALTA® Wireless 5-Input Dry Contact Sensor

Detection Requirements	Input impedance	2.5 MΩ
	Maximum medium impedance	900.0 kΩ <sup>1</sup>
Lead	Cable length	0.9 m (3 ft)
	Wire count	6-conductor (black/white/yellow/red/blue/green)
	Ground Wire	Black
	Input 1 Wire	White
	Input 2 Wire	Yellow
	Input 3 Wire	Red
	Input 4 Wire	Blue
	Input 5 Wire	Green
	Wire gauge	28 AWG
	Conductor material	Stranded Copper
	Insulation	PVC, 0.38mm (0.015")
	Shield	Aluminum; Copper Tinned
	Jacket	PVC (black)
	Overall Diameter	5.4 mm (0.212")
	Ratings / Approvals	UL AWM STYLE 2464, cUL AWM I/IEC RoHS/Reach Compliant
	Temperature Rating	-25°C to 80°C (-13°F to 176°F)
	Voltage Rating	300 V Max <sup>2</sup>
Dielectric Strength	1500 V RMS <sup>2</sup>	
ALTA Wireless	Data logging	Sensor logs 2000 to 4000 readings if gateway connection is lost (non-volatile flash, persists through power cycling): 10-minute Heartbeats = ~22 days - 2-hour Heartbeats = ~266 days
	Wireless protocol	ALTA Proprietary Frequency-Hopping Spread Spectrum (FHSS)
	Wireless transmission power (EIRP)	50 mW (900MHz), 25 mW (868 MHz), 10 mW (433 MHz)
	Wireless range	2,000+ ft. through 18+ walls with the ALTA XL® Gateway
	Security	Encrypt-RF® (256-bit key exchange and AES-128 CTR)
General	Battery voltage range	2.0 to 3.8 VDC
	Operating altitude (non-pressurized)	-15.2 to 1,982 m (-50 to 6,500 ft) <sup>3</sup>
	Storage altitude (non-pressurized environments)	-15.2 to 3,048 m (-50 to 10,000 ft) <sup>3</sup>
	Operating humidity	5 to 85% RH (non-condensing)
	Certifications	900 MHz sensors: FCC ID: ZTL-G2SC1 and IC: 9794A-G2SC1. 868 and 433 MHz sensors tested and comply with: EN 55032: 2015/A11:2020; EN 55035:2017/A11:2020; ETSI EN 300 220 V3.2.1 (2018-06); ETSI EN 301 489-3 V2.2.0. (2021-11); and ETSI EN 303 645. All sensors tested and comply with: EN 61010-1 and EN 60950 and meet RoHS 2015/863 and REACH 224 (June 2022), according to IEC 63000:2016/AMD1:2022.



1. The resistance between the conductive probe ends must be less than this to ensure detection.
2. The input of this sensor is passive. Never apply any voltage to the detection lead.
3. Operating and storage altitude without DC power supply is -30.48 to 9144 m (-100 to 30000 ft).

**Warning:** Use caution when interfacing the ALTA 5-Input Dry Contact Sensors. Any external AC or DC voltages will damage the electronics of the wireless sensor. Monnit is not responsible for troubleshooting, replacing, or reimbursing damages incurred by disregarding this warning.

**The sensor reports five distinct data points:  
Loop Closed or Loop Open  
on Heartbeat or Change.**

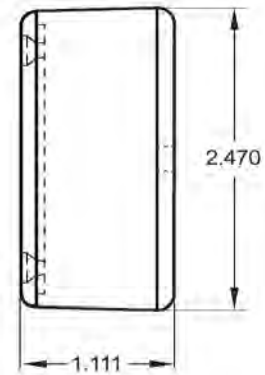
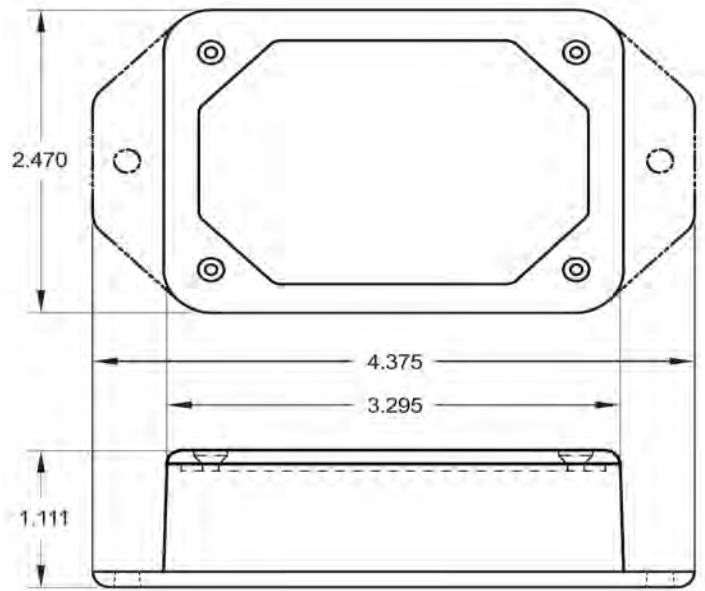

### Technical Specifications | ALTA® Enterprise 5-Input Dry Contact Sensor

Battery <sup>1</sup>	2x 1.5V AA Alkaline, 1500 mAh, (standard) 2x 1.5V AA Lithium, 3000 mAh, (optional)
Battery Life	10+ years expected
Operating temperature range (non-leaded measurement range) <sup>3</sup>	-18°C to 55°C (0°F to 130°F) - AA Alkaline Batteries -25°C to 60°C (-13°F to 140°F) - AA Lithium L91 Batteries 0°C to 40°C (32°F to 104°F) - US 5V Power Supply 10°C to 40°C (50°F to 104°F) - International 5V Power Supply
Wireless antenna type	1/4-wave, 20 gauge wire whip, 3.5" (900/868MHz), 7" (433MHz)
Weight	3.2 oz. (91 g) with 0.3 m (1.0') lead 3.7 oz. (105 g) with 0.9 m (1.0') lead

1. Hardware cannot withstand negative voltage. Please take care when inserting and removing batteries.
2. Operating below 0°C (-32°F) degrees will reduce battery life.

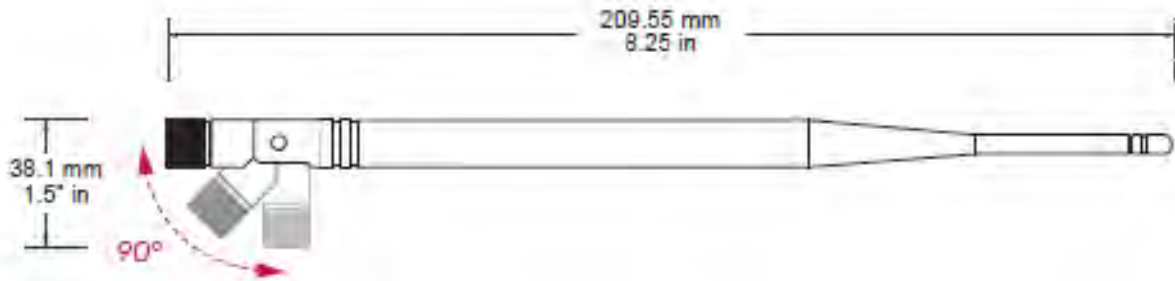
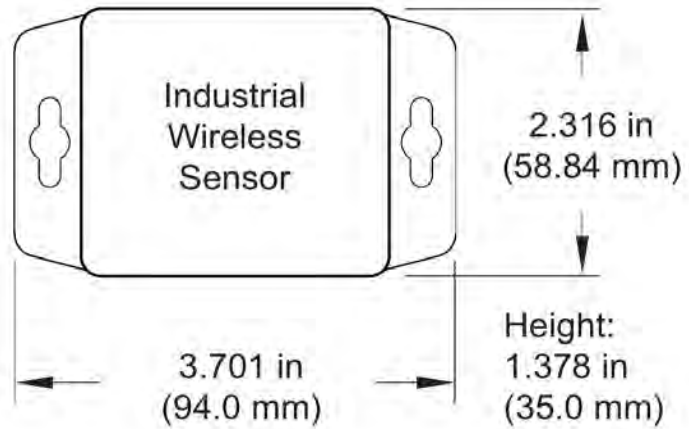

### Technical Specifications | ALTA® Industrial 5-Input Dry Contact Sensor

Battery	1x 3.6V AA Lithium Thionyl Chloride, 2200mAh, pre-installed
Battery Life	10+ years expected
Operating temperature range (non-leaded measurement range) <sup>1</sup>	-40°C to 85°C (-40°F to 185°F)
Wireless antenna type	1/2-wave waterproof dipole with RP-SMA connector and swivel neck; dBi of 3.0 (900/868MHz) or 2.5 (433 MHz); length of 8.27" (210mm) (900/868MHz) or 7.68" (195mm) (433 MHz); diameter at thickest point of 0.55" (14mm)
Weight	4.7 oz. (133 g) with 0.3 m (1.0') lead 5.2 oz. (147 g) with 0.9 m (3.0') lead
Enclosure rating	IP-65 (dust-proof and waterproof but not submersible) NEMA 1, 2, 4, 4x, 12, and 13 rated, sealed, and weatherproof UL Listed to UL508-4x specifications (File E194432)

1. Operating below 0°C (-32°F) degrees will reduce battery life.

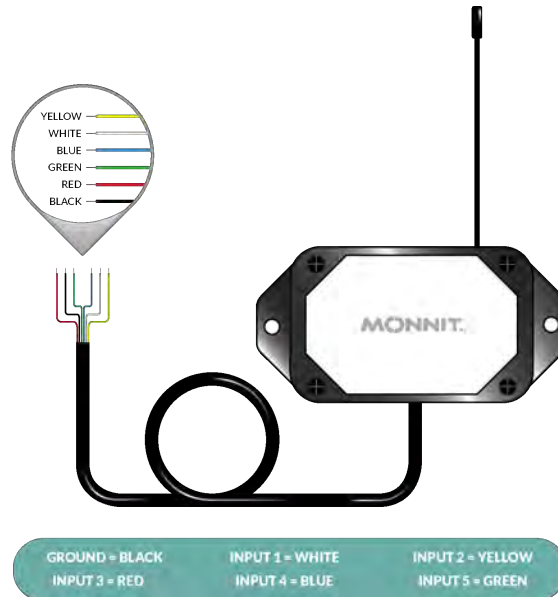

## Commercial-Grade Sensors

Monnit commercial-grade sensors are designed for applications in ordinary environments (normal room temperature, humidity, and atmospheric pressure). Do not use these sensors under the following conditions, as these factors can deteriorate the product characteristics and cause failures and burnout.

- Corrosive gas or deoxidizing gas: chlorine gas, hydrogen sulfide gas, ammonia gas, sulfuric acid gas, nitric oxide gas, etc.
- Volatile or flammable gas
- Dusty conditions
- Low-pressure or high-pressure environments
- Wet or excessively humid locations
- Places with salt water, oils, chemical liquids, or organic solvents
- Where there are excessively strong vibrations
- Other places where similar hazardous conditions exist

Use these products within the specified temperature range. Higher temperatures may cause deterioration of the characteristics or the material quality.

## Industrial-Grade Sensors | Type 1, 2, 4, 4X, 12, and 13 NEMA-Rated Enclosure

Monnit's industrial sensors are enclosed in reliable, weatherproof NEMA-rated enclosures. Our NEMA-rated enclosures are constructed for indoor and outdoor use and protect the sensor circuitry against the ingress of solid foreign objects like dust and the damaging effects of water.

- Safe from falling dirt
- Protects against wind-blown dust
- Protects against rain, sleet, snow, splashing water, and hose-directed water
- Increased level of corrosion resistance
- Will remain undamaged by ice formation on the enclosure



**Monnit Corporation**

3400 South West Temple • Salt Lake City, UT 84115 • 801-561-5555  
www.monnit.com