



ALTA® Wireless Duct Temperature Sensors

General Description

The [ALTA Wireless Duct Temperature Sensor](#) uses an NTC thermistor with 2.67 meter (8') lead wires to accurately measure temperatures in duct work, while maintaining a sealed environment. It can be easily installed and mounted for long-term use.

Key Features

- Measurement Range: -40°C to 150°C (-40°F to 302°F)
- Resolution: 0.1°C (0.18°F)
- Standard Accuracy (at 25°C): ± 1°C (± 1.8°F)
- Calibrated Accuracy (at 25°C): ± 0.25°C (± 0.45°F)
- Accuracy over temperature range: see table below
- Configurable thresholds for critical condition monitoring

Principles of Operation

The ALTA Wireless Duct Temperature Sensor measures duct temperature based on a user-configurable time interval or Heartbeat. When performing a measurement, the sensor momentarily energizes a thermistor in series with a precision resistor. This produces a voltage directly proportional to the temperature of the thermistor. The sensor converts the analog voltage signal to a digital value and computes the temperature measurement. On every Heartbeat, the sensor reports its current measurement to the gateway, making the data available in iMonnit or other approved data services.

The ALTA Wireless Duct Temperature Sensor also can be calibrated for improved accuracy.

Example Applications

- Air duct temperature monitoring
- HVAC operation & testing
- Data center monitoring
- Coolers & freezers
- Environmental monitoring
- Smart machines & smart structures
- [Additional applications](#)

Features of Monnit ALTA Sensors

- Wireless range of 2,000+ feet through 18+ walls¹
- Frequency-Hopping Spread Spectrum (FHSS)
- Best-in-class interference immunity
- Best-in-class power management for longer battery life²
- Encrypt-RF® Security (Diffie-Hellman Key Exchange + Advanced Encryption Standard (AES)-128 Cipher Block Chaining (CBC) for sensor data messages)
- Sensor logs 2000 to 4000 readings if the gateway connection is lost (non-volatile flash, persists through power cycling):
 - 10-minute Heartbeats = ~ 22 days
 - 2-hour Heartbeats = ~ 266 days
- Automatic over-the-air updates to sensor firmware (future-proof)
- Free iMonnit Basic Online Wireless Sensor Monitoring and Notification System to configure sensors, view data, and send alerts via SMS text, email, and voice call

¹ Actual range may vary depending on the environment and gateway.

² Battery life is determined by the sensor reporting frequency and other variables. Other power options are also available.

Wireless Range Comparison

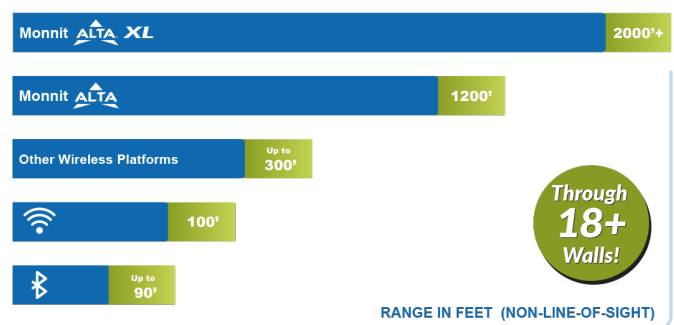

Technical Specification | ALTA® Wireless Thermocouple Sensors

Temperature Measurement	Range - Leaded sensor	-40°C to 150°C (-40°F to 302°F)
	Accuracy @ 0°C (32°F)	± 1°C (±1.8°F)
	Calibrated accuracy @ 0°C (32°F)	± 0.25°C (± 0.45°F)
	Resolution	0.1°C (0.18°F)
Leaded Probe	Transducer type	NTC Thermistor
	Tip dimension	6.35 mm (0.25") diameter by 101.6 mm (4")
	Tip material	Type 304 stainless steel
	Cable material	Plenum
	Cable diameter	3.18 mm (.125")
	Cable length options	Standard length: 2.4 m (8 ft)
ALTA Wireless	Data logging	Sensor logs 2000 to 4000 readings if gateway connection is lost (non-volatile flash, persists through power cycling): 10-minute Heartbeats = ~22 days - 2-hour Heartbeats = ~266 days
	Wireless protocol	ALTA Proprietary Frequency-Hopping Spread Spectrum (FHSS)
	Wireless transmission power (EIRP)	50 mW (900MHz), 25 mW (868 MHz), 10 mW (433 MHz)
	Wireless range	2,000+ ft. through 18+ walls with the ALTA XL® Gateway
General	Security	Encrypt-RF® (256-bit key exchange and AES-128 CTR)
	Battery voltage range	2.0 to 3.8 VDC
	Operating altitude (non-pressurized environments)	-15.2 to 1,982 m (-50 to 6,500 ft) ²
	Storage altitude (non-pressurized environments)	-15.2 to 3,048 m (-50 to 10,000 ft) ²
	Operating humidity	5 to 85% RH (non-condensing)
	Certifications	900 MHz sensors: FCC ID: ZTL-G2SC1 and IC: 9794A-G2SC1 . 868 and 433 MHz sensors tested and comply with: EN 55032: 2015/A11:2020; EN 55035:2017/A11:2020; ETSI EN 300 220 V3.2.1 (2018-06); ETSI EN 301 489-3 V2.2.0. (2021-11); and ETSI EN 303 645 . All sensors tested and comply with: EN 61010-1 and EN 60950 and meet RoHS 2015/863 and REACH 224 (June 2022) , according to IEC 63000:2016/AMD1:2022 .



1. Response time defined as five time constants for 99.3% of actual temperature.
2. Operating and storage altitude without DC power supply is -30.48 to 9144 m (-100 to 30000 ft).

The sensor reports the temperature (in °C or °F) of the thermistor.

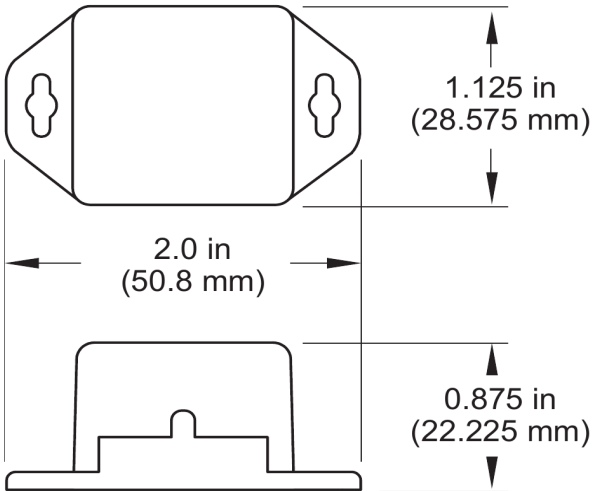
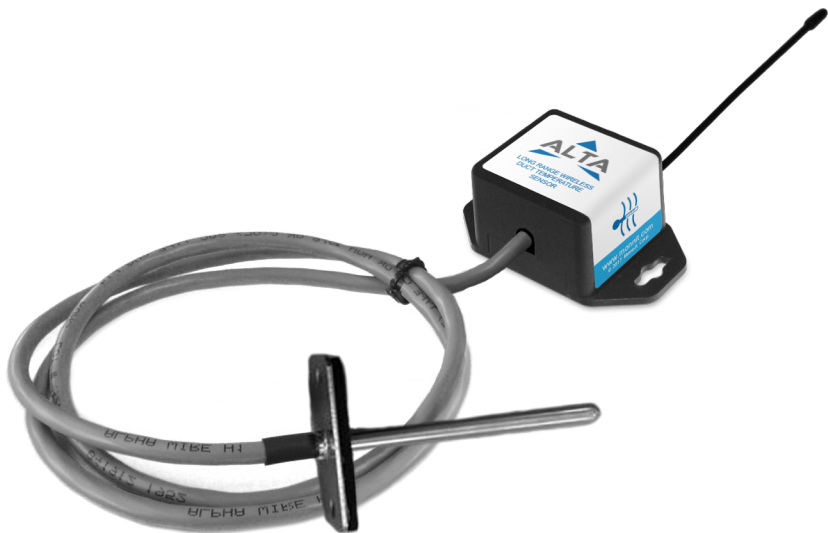

PinchPower™ Enclosures

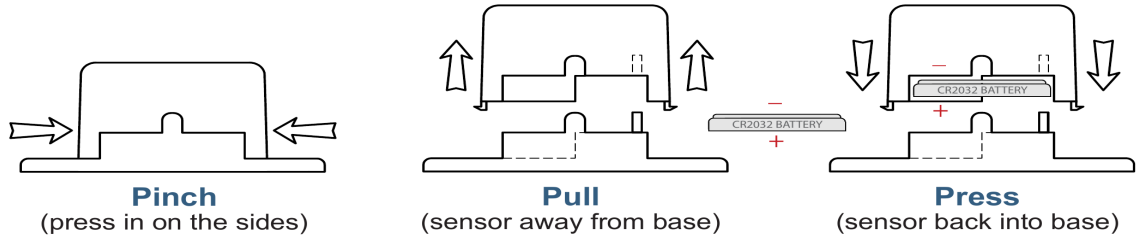

Technical Specifications | ALTA® Commercial

Battery ¹	1x 3.0V CR2032 Button Cell, 100 mAh
Battery Life	2+ years expected
Operating temperature range (non-leaded measurement range)	10°C to 50°C (50°F to 122°F)
Wireless antenna type	1/4-wave, 20 gauge wire whip, 3.5" (900/868MHz), 7" (433MHz)
Weight	0.4 oz. (11.34 g) with no lead 1.34 oz. (37.99 g) with 0.9 m (3.0') lead

1. Hardware cannot withstand negative voltage. Please take care when inserting and removing battery.

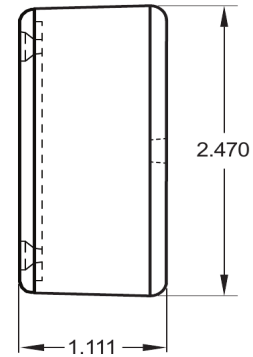
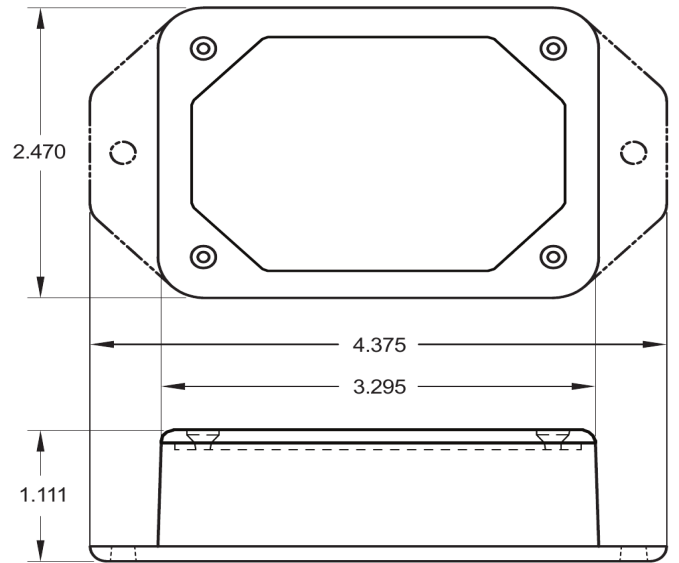
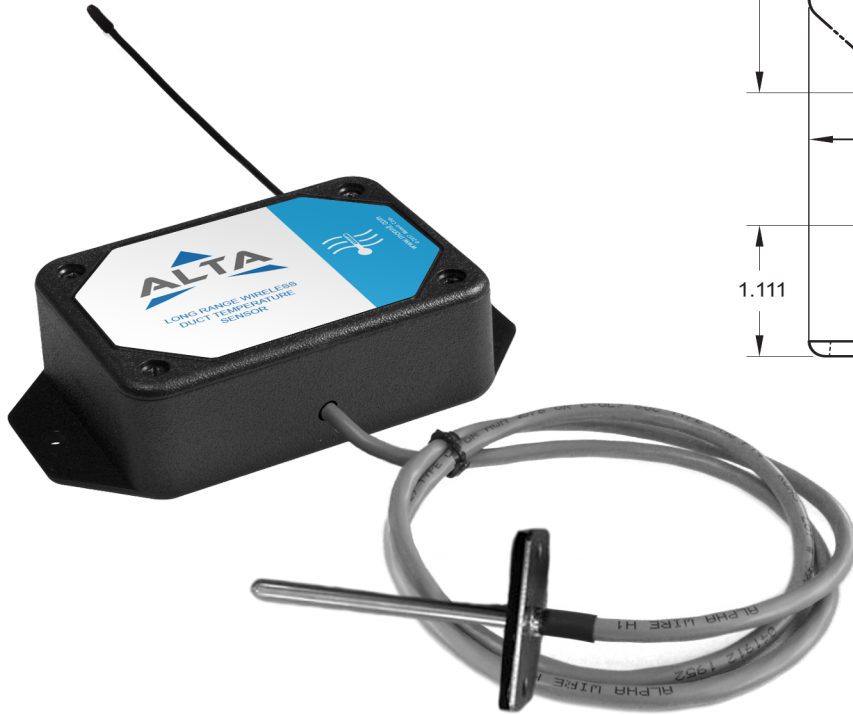

Technical Specifications ALTA® Enterprise	
Battery ¹	2x 1.5V AA Alkaline, 1500 mAh, (standard) 2x 1.5V AA Lithium, 3000 mAh, (optional)
Battery Life	10+ years expected
External line-power option ²	Input voltage: 5.0-12.0 V Power jack: 2.1 x 5.5 mm barrel, center positive
Operating temperature range (non-leaded measurement range) ³	-18°C to 55°C (0°F to 130°F) - AA Alkaline Batteries -25°C to 60°C (-13°F to 140°F) - AA Lithium L91 Batteries 0°C to 40°C (32°F to 104°F) - US 5V Power Supply 10°C to 40°C (50°F to 104°F) - International 5V Power Supply
Wireless antenna type	1/4-wave, 20 gauge wire whip, 3.5" (900/868MHz), 7" (433MHz)
Weight	3 oz. (85.05 g) with no lead 3.7 oz. (105 g) with 0.9 m (3.0') lead

1. Hardware cannot withstand negative voltage. Please take care when inserting and removing batteries.
2. Batteries will provide backup power in the case the external power is removed.
3. Operating below 0°C (-32°F) degrees will reduce battery life.

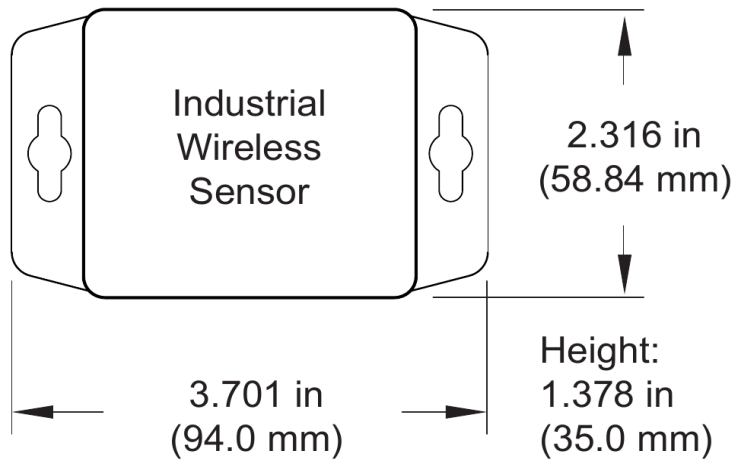
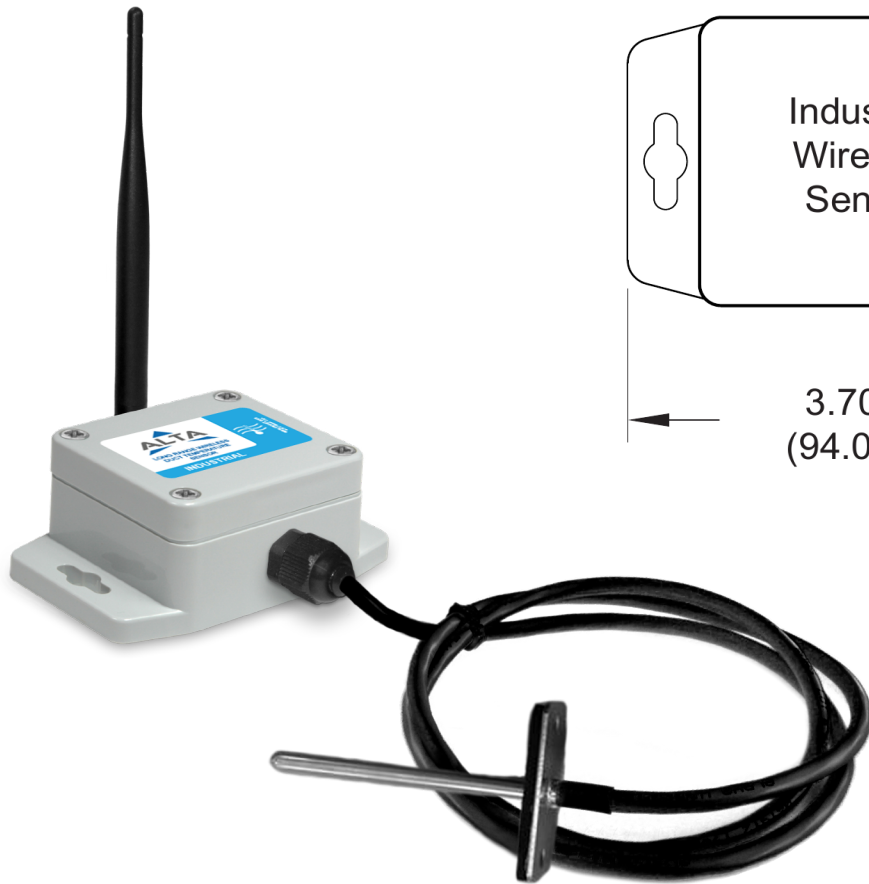
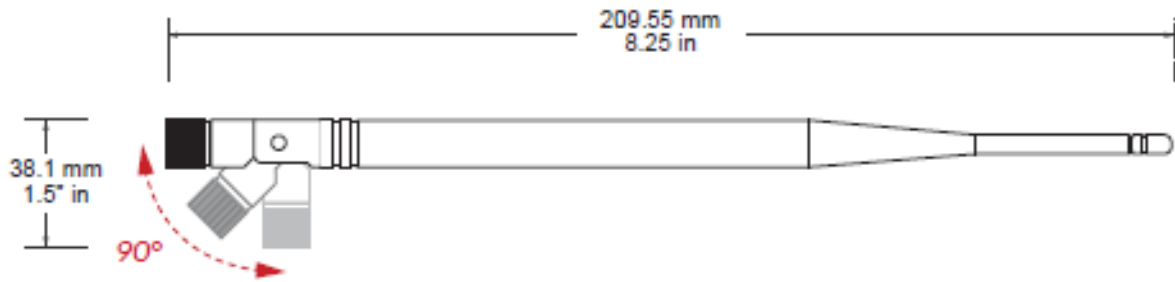

Technical Specifications ALTA® Industrial	
Battery	1x 3.6V AA Lithium Thionyl Chloride, 1500mAh, pre-installed
Battery Life	10+ years expected
Operating temperature range (non-leaded measurement range) ¹	-40°C to 85°C (-40°F to 185°F)
Wireless antenna type	1/2-wave waterproof dipole with RP-SMA connector and swivel neck; dBi of 3.0 (900/868MHz) or 2.5 (433 MHz); length of 8.27" (210mm) (900/868MHz) or 7.68" (195mm) (433 MHz); diameter at thickest point of 0.55" (14mm)
Weight	4.7 oz. (133 g) with 0.15 m (6.0") lead 5.2 oz. (147 g) with 0.9 m (3.0') lead
Enclosure rating	IP-65 (dust-proof and waterproof but not submersible) NEMA 1, 2, 4, 4x, 12, and 13 rated, sealed, and weatherproof UL Listed to UL508-4x specifications (File E194432)

1. Operating below 0°C (-32°F) degrees will reduce battery life.

Commercial-Grade Sensors

Monnit commercial-grade sensors are designed for applications in ordinary environments (normal room temperature, humidity, and atmospheric pressure). Do not use these sensors under the following conditions, as these factors can deteriorate the product characteristics and cause failures and burnout.

- Corrosive gas or deoxidizing gas: chlorine gas, hydrogen sulfide gas, ammonia gas, sulfuric acid gas, nitric oxide gas, etc.
- Volatile or flammable gas
- Dusty conditions
- Low-pressure or high-pressure environments
- Wet or excessively humid locations
- Places with salt water, oils, chemical liquids, or organic solvents
- Where there are excessively strong vibrations
- Other places where similar hazardous conditions exist

Use these products within the specified temperature range. Higher temperatures may cause deterioration of the characteristics or the material quality.

Industrial-Grade Sensors | Type 1, 2, 4, 4X, 12, and 13 NEMA-Rated Enclosure

Monnit's industrial sensors are enclosed in reliable, weatherproof NEMA-rated enclosures. Our NEMA-rated enclosures are constructed for indoor and outdoor use and protect the sensor circuitry against the ingress of solid foreign objects like dust and the damaging effects of water.

- Safe from falling dirt
- Protects against wind-blown dust
- Protects against rain, sleet, snow, splashing water, and hose-directed water
- Increased level of corrosion resistance
- Will remain undamaged by ice formation on the enclosure



Monnit Corporation

3400 South West Temple • Salt Lake City, UT 84115 • 801-561-5555
www.monnit.com