



ALTA® Wireless High Temperature Sensors

General Description

The [ALTA® Wireless High Temperature Sensor](#) uses a glass-coated platinum resistance temperature detector (RTD) to measure temperature accurately. This sensor comes in various lead lengths and operates in high-temperature, dry, and low-humidity environments.

Key Features

- Measurement Range: -50°C to 370°C (-58°F to +700°F)
- Resolution: 0.1°C (0.18°F)
- Standard Accuracy (at 0°C): ± 3.3°C (± 5.9°F)
- Calibrated Accuracy (at 0°C): ± 0.5°C (± 0.9°F)
- Accuracy over temperature range: see table below
- Configurable thresholds for critical condition monitoring

Principles of Operation

The ALTA Wireless High Temperature Sensor measures the ambient temperature based on a user-configurable time interval or Heartbeat. When performing a measurement, the sensor momentarily energizes a platinum Resistance Temperature Detector or RTD in series with a precision resistor. This produces a voltage directly proportional to the temperature of the RTD. The sensor converts the analog voltage signal to a digital value and computes the temperature measurement. On every Heartbeat, the sensor reports its current measurement to the gateway, making the data available in iMonnit or other approved data services.

The ALTA High Temperature Sensor also can be calibrated for improved accuracy.

Example Applications

- Heaters & boilers
- Ovens & cooking devices
- Environmental monitoring
- Smart machines & smart structures
- HVAC operation & testing
- [Additional applications](#)

Features of Monnit ALTA Sensors

- Wireless range of 2,000+ feet through 18+ walls¹
- Frequency-Hopping Spread Spectrum (FHSS)
- Best-in-class interference immunity
- Best-in-class power management for longer battery life²
- Encrypt-RF® Security (Diffie-Hellman Key Exchange + Advanced Encryption Standard (AES)-128 Cipher Block Chaining (CBC) for sensor data messages)
- Sensor logs 2000 to 4000 readings if the gateway connection is lost (non-volatile flash, persists through power cycling):
 - 10-minute Heartbeats = ~ 22 days
 - 2-hour Heartbeats = ~ 266 days
- Automatic over-the-air updates to sensor firmware (future-proof)
- Free iMonnit Basic Online Wireless Sensor Monitoring and Notification System to configure sensors, view data, and send alerts via SMS text, email, and voice call

¹ Actual range may vary depending on the environment and gateway.

² Battery life is determined by the sensor reporting frequency and other variables. Other power options are also available.

Wireless Range Comparison

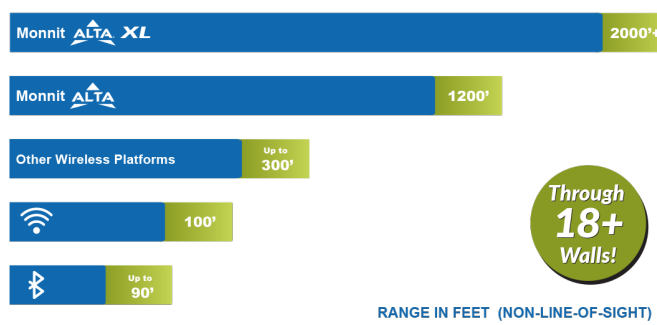

Technical Specification | ALTA® Wireless High Temperature Sensors

Temperature Measurement	Range - Leaded sensor	-50°C to 370°C (-58°F to 700°F)
	Accuracy @ 0°C (32°F)	± 3.3°C (±5.9°F)
	Calibrated accuracy @ 0°C (32 °F)	± 0.5°C (± 0.9°F)
	Resolution	0.1°C (0.18°F)
	Response time	50 seconds (10 second time constant) ¹
Leaded Probe	Transducer type	Glass-coated platinum RTD, IEC 751-95 Class A
	Tip dimension	4.76 mm (0.1875") diameter by 35 mm (1.38")
	Tip material	Type 304 stainless steel
	Cable material	Glass Braid
	Cable diameter	1.5 x 2.4 mm (.060" x 0.095")
	Cable length	Standard: 0.9m (3 ft) Option: 3m (10ft), 7.5m (25 ft)
ALTA Wireless	Data logging	Sensor logs 2000 to 4000 readings if gateway connection is lost (non-volatile flash, persists through power cycling): 10-minute Heartbeats = ~22 days - 2-hour Heartbeats = ~266 days
	Wireless protocol	ALTA Proprietary Frequency-Hopping Spread Spectrum (FHSS)
	Wireless transmission power (EIRP)	50 mW (900MHz), 25 mW (868 MHz), 10 mW (433 MHz)
	Wireless range	2,000+ ft. through 18+ walls with ALTA XL® Gateway
	Security	Encrypt-RF® (256-bit key exchange and AES-128 CTR)
General	Battery voltage range	2.0 to 3.8 VDC
	Operating altitude (non-pressurized environments)	-15.2 to 1,982 m (-50 to 6,500 ft) ²
	Storage altitude (non-pressurized environments)	-15.2 to 3,048 m (-50 to 10,000 ft) ²
	Operating humidity	5 to 85% RH (non-condensing)
	Certifications	900 MHz sensors: FCC ID: ZTL-G2SC1 and IC: 9794A-G2SC1 . 868 and 433 MHz sensors tested and comply with: EN 55032: 2015/A11:2020 ; EN 55035:2017/A11:2020 ; ETSI EN 300 220 V3.2.1 (2018-06) ; ETSI EN 301 489-3 V2.2.0. (2021-11) ; and ETSI EN 303 645 . All sensors tested and comply with: EN 61010-1 and EN 60950 and meet RoHS 2015/863 and REACH 224 (June 2022) , according to IEC 63000:2016/AMD1:2022 .

1. Response time defined as five time constants for 99.3% of actual temperature.
2. Operating and storage altitude without DC power supply is -30.48 to 9144 m (-100 to 30000 ft).

RTD Accuracy Over Temperature

Temperature (°C)	Accuracy (±°C)		
	Uncalibrated Sensor	Calibrated Sensor	IEC 751-95 Class A RTD Only
-50°C	3.4	0.750	0.25
-25°C	3.35	0.625	0.20
0°C	3.30	0.500	0.15
25°C	3.35	0.625	0.20
50°C	3.4	0.750	0.25
75°C	3.45	0.875	0.30
100°C	3.5	1.000	0.35
125°C	3.55	1.125	0.40
150°C	3.60	1.250	0.45
175°C	3.65	1.375	0.50
200°C	3.70	1.500	0.55
225°C	3.75	1.625	0.60
250°C	3.80	1.750	0.65
275°C	3.85	1.875	0.70
300°C	3.90	2.000	0.75
325°C	3.95	2.125	0.80
350°C	4.00	2.250	0.85

The sensor reports the temperature (in °C or °F) of the RTD.

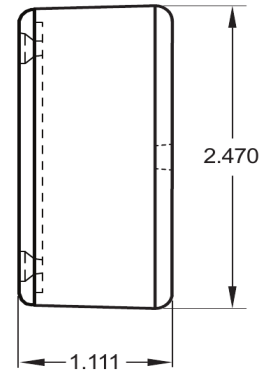
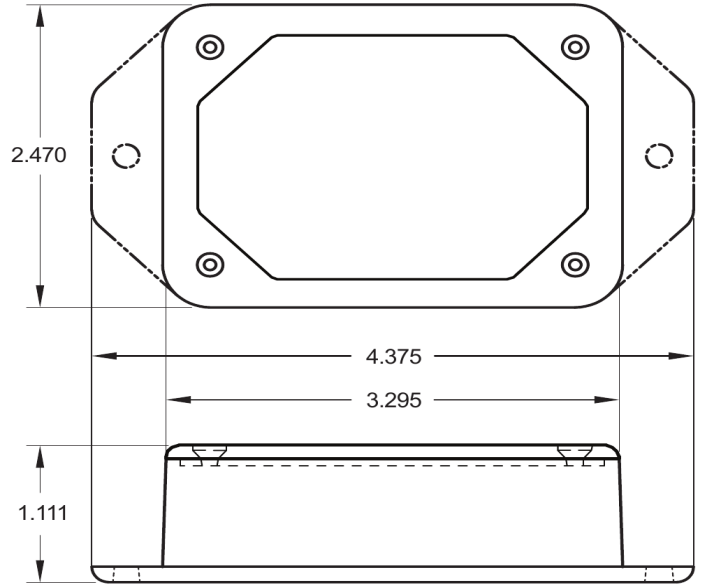

Technical Specifications ALTA® Enterprise	
Battery ¹	2x 1.5V AA Alkaline, 1800 mAh, (standard) 2x 1.5V AA Lithium, 3000 mAh, (optional)
Battery Life	10+ years expected
External line-power option ²	Input voltage: 5.0-12.0 V Power jack: 2.1 x 5.5 mm barrel, center positive
Operating temperature range (sensor body) ³	-18°C to 55°C (0°F to 130°F) - AA Alkaline Batteries -25°C to 60°C (-13°F to 140°F) - AA Lithium L91 Batteries 0°C to 40°C (32°F to 104°F) - US 5V Power Supply 10°C to 40°C (50°F to 104°F) - International 5V Power Supply
Wireless antenna type	1/4-wave, 20 gauge wire whip, 3.5" (900/868MHz), 7" (433MHz)
Weight	3.7 oz. (105 g)

1. Hardware cannot withstand negative voltage. Please take care when inserting and removing batteries.
2. Batteries will provide backup power in the case the external power is removed.
3. Operating below 0°C (-32°F) degrees will reduce battery life.

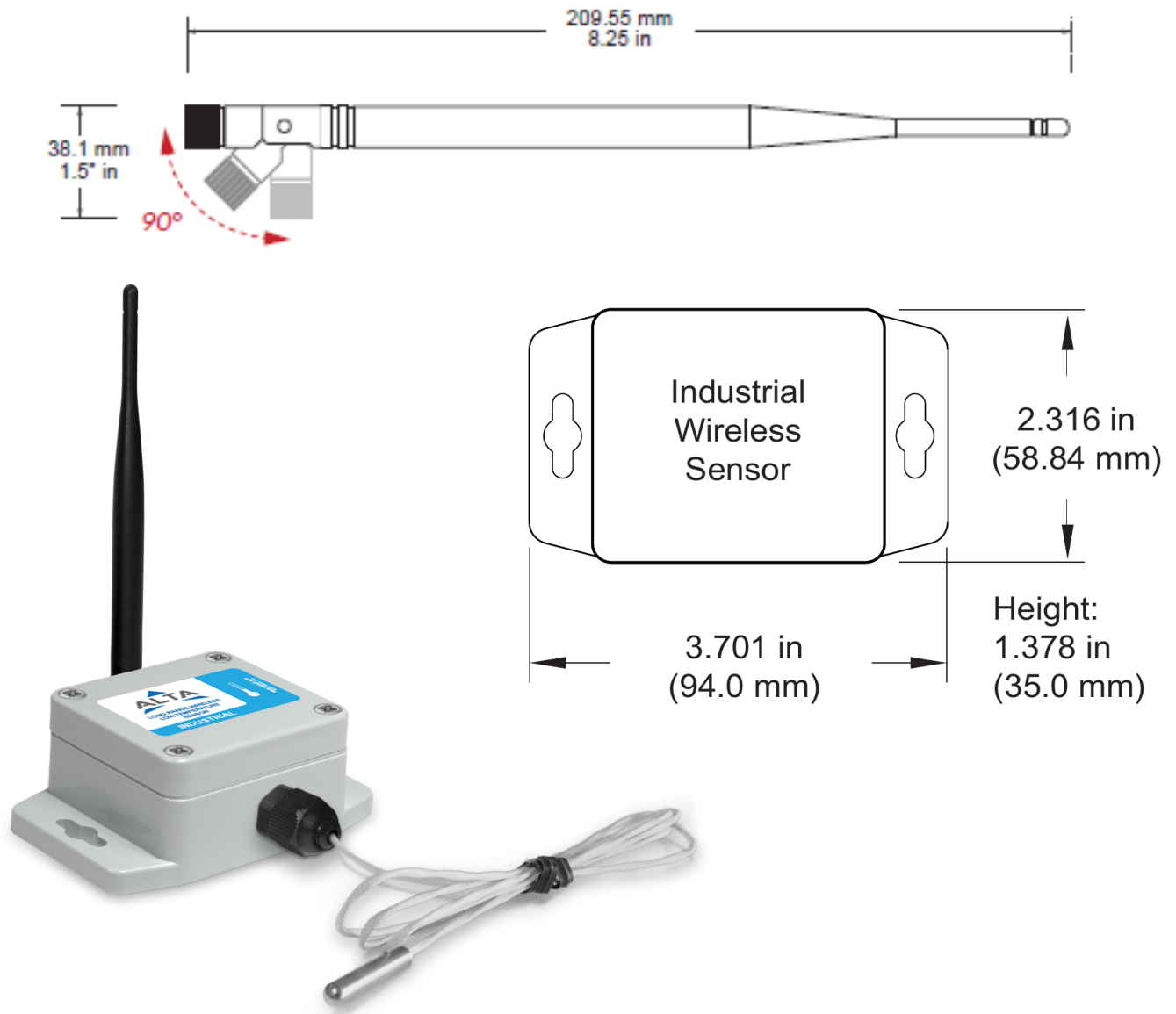

Technical Specifications ALTA® Industrial	
Battery	1x 3.6V AA Lithium Thionyl Chloride, 1500mAh, pre-installed
Battery Life	10+ years expected
Operating temperature range (sensor body) ¹	-40°C to 85°C (-40°F to 185°F)
Wireless antenna type	1/2-wave waterproof dipole with RP-SMA connector and swivel neck; dBi of 3.0 (900/868MHz) or 2.5 (433 MHz); length of 8.27" (210mm) (900/868MHz) or 7.68" (195mm) (433 MHz); diameter at thickest point of 0.55" (14mm)
Weight	4.7 oz. (133 g)
Enclosure rating	IP-65 (dust-proof and waterproof but not submersible) NEMA 1, 2, 4, 4x, 12, and 13 rated, sealed, and weatherproof UL Listed to UL508-4x specifications (File E194432)

1. Operating below 0°C (-32°F) degrees will reduce battery life.

Commercial-Grade Sensors

Monnit commercial-grade sensors are designed for applications in ordinary environments (normal room temperature, humidity, and atmospheric pressure). Do not use these sensors under the following conditions, as these factors can deteriorate the product characteristics and cause failures and burnout.

- Corrosive gas or deoxidizing gas: chlorine gas, hydrogen sulfide gas, ammonia gas, sulfuric acid gas, nitric oxide gas, etc.
- Volatile or flammable gas
- Dusty conditions
- Low-pressure or high-pressure environments
- Wet or excessively humid locations
- Places with salt water, oils, chemical liquids, or organic solvents
- Where there are excessively strong vibrations
- Other places where similar hazardous conditions exist

Use these products within the specified temperature range. Higher temperatures may cause deterioration of the characteristics or the material quality.

Industrial-Grade Sensors | Type 1, 2, 4, 4X, 12, and 13 NEMA-Rated Enclosure

Monnit's industrial sensors are enclosed in reliable, weatherproof NEMA-rated enclosures. Our NEMA-rated enclosures are constructed for indoor and outdoor use and protect the sensor circuitry against the ingress of solid foreign objects like dust and the damaging effects of water.

- Safe from falling dirt
- Protects against wind-blown dust
- Protects against rain, sleet, snow, splashing water, and hose-directed water
- Increased level of corrosion resistance
- Will remain undamaged by ice formation on the enclosure



Monnit Corporation

3400 South West Temple • Salt Lake City, UT 84115 • 801-561-5555
www.monnit.com